

LFP 5-10kWh / LV

51.2V 100/200Ah

RECHARGEABLE LITHIUM BATTERY



High inverter compatibility



Bluetooth responds quickly



Scalable up to 160kWh 16 (Parallel)



Cells cycle times 6000 cycles



CANbus standard connection



IP65 Rating Triple hardware protection



Smart BMS system to optimize the performance

 **SUNKET - ESS**

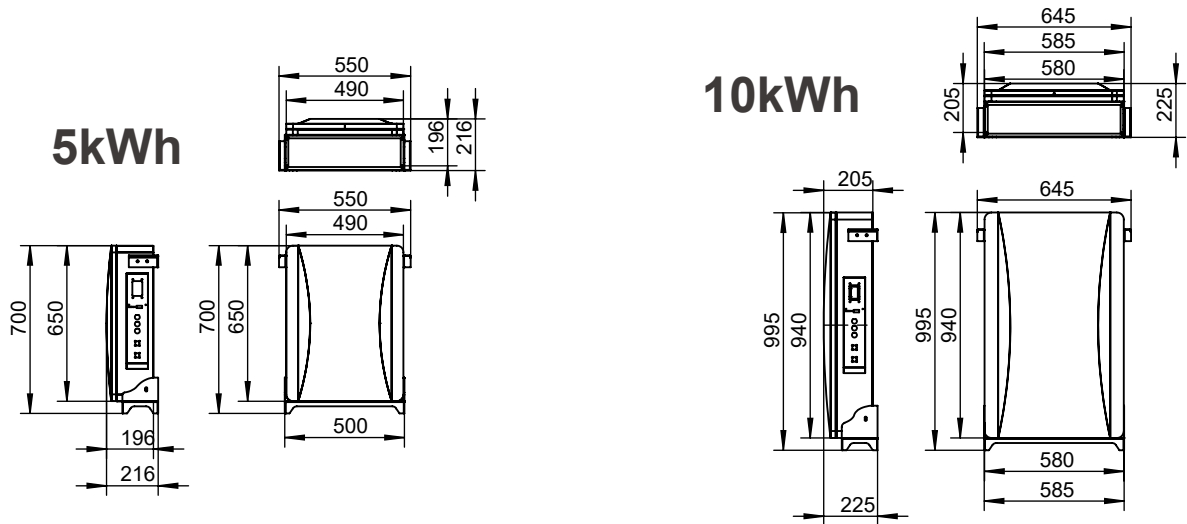

Electrical Characteristics

LFP 5-10kWh / LV

Module Type	LFP 5kWh / LV	LFP 10kWh / LV
Nominal Capacity (at 25 °C)	5.12kWh	10.24kWh
Usable Capacity (90%DOD)	4.6kWh	9.2kWh
Nominal Dis-/Charge Power	2.5kW	5kW
Peak Power(Only Discharge)	2.9kW for 3 seconds	5.8kW for 3 seconds
Constant Current(Only Discharge)	50A	100A
Operating Voltage Range (V)	43.2~58.4V	43.2~58.4V
Nominal Voltage	51.2Vd.c	51.2Vd.c
Weight	58kg	109kg
Dimension(mm)	490(550)*650(700)*196(216)mm	585(645)*940(995)*205(225)mm
Certificates	CE,UN38.3,IEC62619,IEC63056	CE,UN38.3,IEC62619,IEC63056
Operating Condition	Indoor or outdoor	
Operating Temperature Charge	0~45 °C	
Operating Temperature Discharge	-10~50 °C	
Humidity	Up to 90% (non- condensing)	
Pollution Degree	3	
Over Voltage Category	II	
Cooling Type	Natural cooling	
IP Rating	IP 65	
Protective Class	I	
Max. Number of Parallel	16	
Warranty	10 years	
Life Span	>15 years	
Communication Interface	CAN / RS485	
Protection Mode	Triple hardware protection	
Battery Protection	Over-current / Over-voltage / Short circuit / Under-voltage	

Compatible Inverters



Battery	Description
---------	-------------

Standard configuration:

① Communication Line x1
② Expansion Bolt x4
③ Screw M5 x4
④ Screw M6 x4
⑤ USB to RS-485 Converter x1
⑥ Waterproof Connector x3

⑦ Retainer x2
⑧ Mounting Bracket x1
⑨ Red Power Cable x1
⑩ Black Power Cable x1
⑪ User Manual x1
⑫ Quality Report x1



Low Voltage 5-10kWh Hybrid PV System:

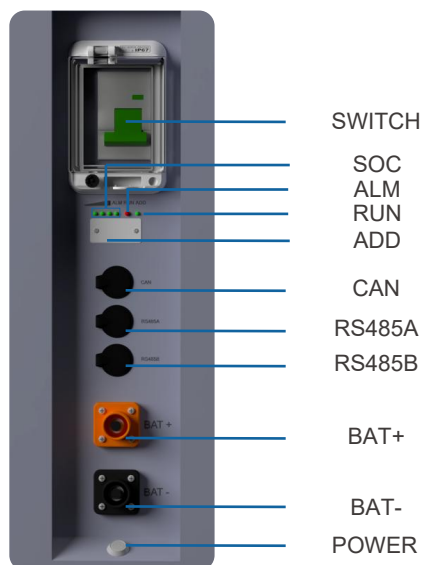
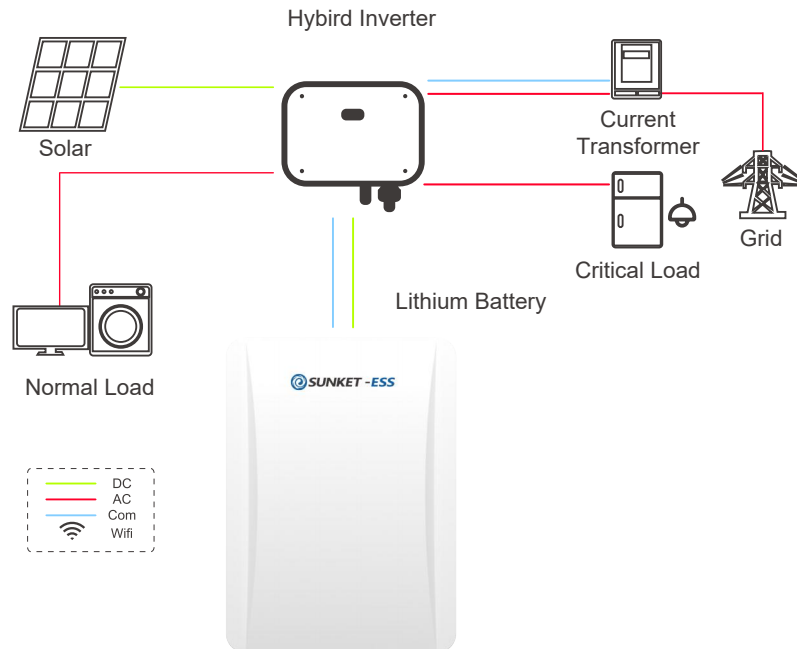

- SWITCH: On or off the current circuit
- SOC: The number of green lights shows the remaining power
- ALM: Red LED lighting to show the battery has been alarmed
- RUN: Green LED lighting to show the battery running status
- ADD: DIP switch
- CAN: Inverter communication
- RS485A: RS45 interface, used for battery parallel communication, connecting RS485B of another battery
- RS485B: RS45 interface, used for battery parallel communication, connecting RS485A of another battery
- BAT+: Battery positive terminal connection position
- BAT-: Battery negative terminal connection position
- POWER: Power on or off the control battery

Battery Description

APP



Bluetooth APP Monitoring



Portable Control



Low Power (Bluetooth LE)



Local monitoring mode for battery

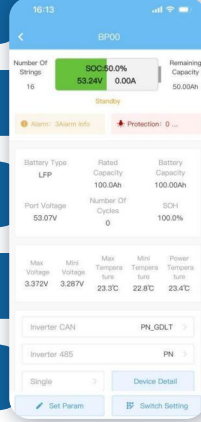

Quick Pairing



No Internet Needed

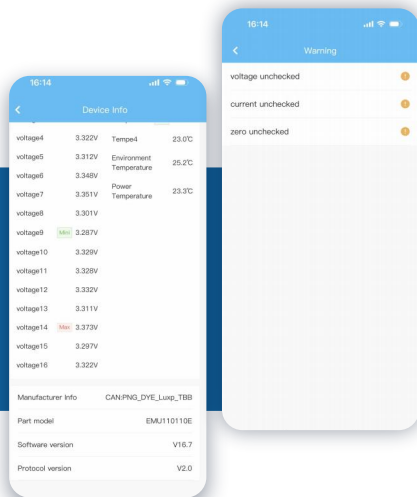

Intelligent Data Analysis



Real-time Equipment Monitoring

Packing Configuration

8
PIECES
PALLET

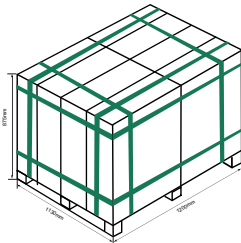

8/6
PIECES
PALLET

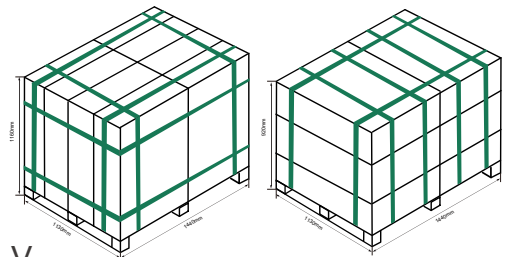

LFP 5kWh / LV

Pallet Dimensions	1200x1130x875mm	
Container	20'GP	40'HQ
Pieces per Pallet	8	8
Pallets per Container	16	36
Pieces per Container	128	288

LFP 10kWh / LV

Pallet Dimensions	1440x1130x1160(920)mm	
Container	20'GP	40'HQ
Pieces per Pallet	8/6	8
Pallets per Container	8(6pcs/pallet)+6(6pcs/pallet)	28
Pieces per Container	96	224